

General

Upgradable for future communication needs: flexible remote communication modules without breaking approval seal. The new series of modules for domestic use puts promises into practice, paving the way not only for multi-energy applications but also for new services in personal energy management.

This specification details the operation and the electrical requirements for connection of an AMR module with M-Bus interface to the L+G E350 (ZxF series 100) meter.

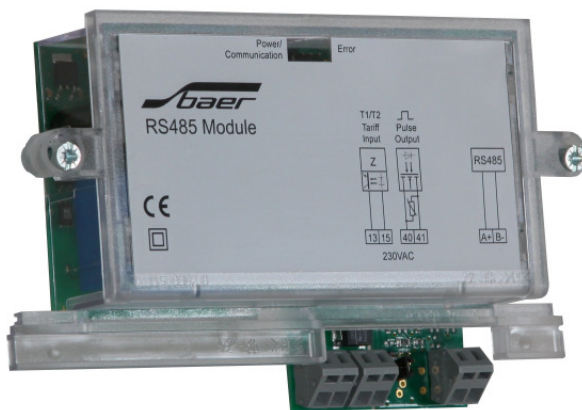

Compatible meters

- ZCF110/120 single phase meter
- ZMF110/120 multiphase meter
- ZFF110/120 multiphase meter

Functions

The AMR interface contains the following functions:

- Bi-directional communications: an integrated M-Bus (2 wires, passive) interface provides a simple means of connecting multi-energy meters. This makes multi-energy applications an affordable proposition for domestic use. Transmission protocol: IEC 62056-21
- Rate input for tariff switching via external control inputs
- Pulse output (with pulse rate change)
- Internal communication interface for the transfer billing data between the meter and AMR module (every 10 seconds).

For details of the communications protocol, refer to the software interface specification (IEC 62056-21 and OBIS Codes).

- Phase connections to one phase (230VAC)

Safety Notes



The owner of the AMR modules is responsible that all persons engaged on work with the modules:

- Are competent and qualified in accordance with national regulations (see ISSA "Guideline for Assessing the Competence of Electrically Skilled Persons").
- Have read and understood the relevant sections of the user manual.
- Strictly observe the safety regulations (according to the following section) and the instructions in the individual chapters.

The owner of the modules is also responsible for:

- The protection of persons.
- The prevention of material damage.
- The training of personnel.

The following safety regulations must be observed at all times:

- Devices which have fallen down should not be installed, even if no damage is apparent, and should be returned for testing to an authorised service centre (internal damage possible).
- Modules must never be cleaned with running water or high pressure devices. Water can cause short-circuits or damage el. components.

Installation Hints

The installation must be done in a way, that even in the case of cable break no dangerous voltages are applied to touchable parts of the module. Generally, meters are delivered with the communication modules installed. The fitting of a meter with a communication module is, therefore, an exception and can be necessary e.g. when a module needs to be replaced.

NEVER remove the AMR module when the device is powered!

Disconnect meter from mains before inserting the module.

In order to avoid hazardous electric shocks, ensure there is no voltage applied to the meter when fitting the communication module.

Fit the AMR module in the meter as follows:

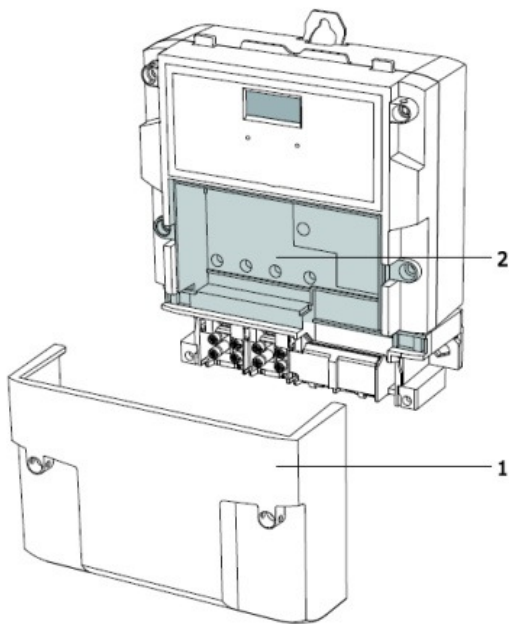

Ensure that the meter is disconnected from mains.
Remove the utility seals on the terminal cover and the AMR module cover.

Remove the terminal cover (1).
Remove the AMR module (2).

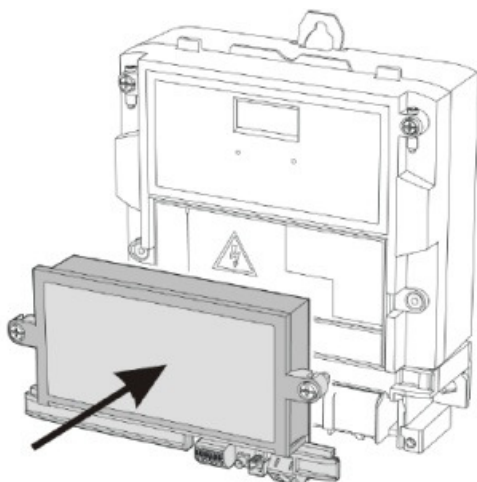

Insert the AMR module carefully at the place provided in the meter. Ensure the connector pins are not bent when the module is pushed down.
Tighten and seal the 2 screws of the AMR module.

The connections are marked on the faceplate.

Rate Input

The module provides a single optically isolated rate input.

Maximum voltage: 230VAC (-20% / +15%) / 2mA

Function: no voltage on the rate input: T1 (register 1.8.1 active), default
with voltage on the rate input: T2 (register 1.8.2 active)

Pulse Output

The pulse output circuit appears as an open-collector from an opto-isolator.

Maximum voltage: 265VAC/DC

Maximum reading rate: 1ms

Communication Parameter

Some jumper blocks are used for setting the communication parameter.

Note: set the jumper before switch-on.

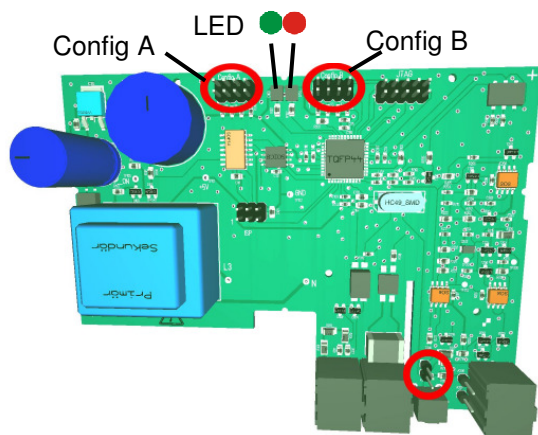

Jumper Block "Config A"

Jumper block "Config A" (left site) is used for setting the baud rate and the data format for the M-Bus interface:

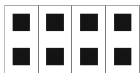
	Jumper Config A	1	2	3	4
	Function	8N1	8E1	4800 baud	2400 baud

Default (without jumpers): 9600 baud, 7E1

Set the jumper for activation:

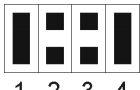

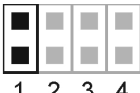
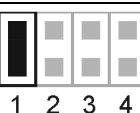

	Example for 2400 baud, 8N1: set the jumpers 1 and 4
---	---

Jumper Block "Config B"

Jumper 1 is used for setting the timeout for acknowledge (according to specification for IEC 62056-21):

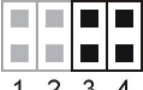



	Without jumper: 2 seconds
	With jumper: 15 seconds (for readout via GPRS)

Jumper 3 and/or 4 is used for setting the pulse rate for the pulse output:

 <p>1 2 3 4</p>	<p>1/1: without jumpers: without pulse rate change (see meter setup) minimum pulse length: 2ms</p>
 <p>1 2 3 4</p>	<p>1/10: pulse rate 1/10; pulse length 20ms</p>
 <p>1 2 3 4</p>	<p>1/20: pulse rate 1/10; pulse length 40ms</p>
 <p>1 2 3 4</p>	<p>1/40: pulse rate 1/10; pulse length 80ms</p>

LED Displays

Two LED's display the current operating status of the module and give information about the data transfer.

- Power:  on: AMR module is supplied with power
-  flashed: communication via M-Bus interface
- Error:  on: communication error between AMR module and meter
-  off: no errors

Communication

The AMR port is conforming to IEC 62056-21 with fixed baud rate;

For reading data the meter-ID (device address) can be used (e.g. /?<meter-ID>!);

Length of telegrams (data readout): 745 bytes max.

Example for communication path:

```

Sign-on sequence:      /! ? CR LF           without meter-ID
                        or  /? 12345678! CR LF       if the meter-ID := 12345678

Answer:                /LGZz Ident CR LF

Sign-on acknowledgement: ACK 0z0 CR LF

Data readout (billing list):
                        F.F(00)
                        C.1.0(12345678
                        0.0(12345678   )
                        C.1.1(94858005)
                        1.8.0(0000750.3*kWh)
                        1.8.1(0000000.0*kWh)
                        1.8.2(0000750.3*kWh)
                        2.8.0(0000002.8*kWh)
                        32.7(233*V)
                        52.7(233*V)
                        72.7(233*V)
                        C.5.0(3A) ...
                        !
    
```

Technical data:

Housing:	Polycarbonate housing with terminals for using with Landis+Gyr E350 meters (L+G ZxF domestic meters)
Degree of protection:	IP52 (according to IEC 60529)
Protection class:	2
Dimensions:	165mm x 90mm x 33mm (W x H x D)
Nominal voltage:	230VAC (-20% / +15%) / 50Hz connection spring for one phase: Live (L1) and Neutral (N) from meter
Power consumption:	ca. 2,8W
Temperature range:	-45 °C to +65 °C (operational) -45 °C to +90 °C (storage temperature)
LED displays:	2 LED's: ● green: Power ● red: Error
Interface:	M-Bus (2 wires, passive) according to EN 13757-2 (physical layer)
Baud rate:	2400, 4800 or 9600 baud; default: 9600 baud (fixed baud rate)
Data format:	7E1, 8N1, 8E1; default: 7E1
Transmission protocol:	IEC 62056-21 (conform to VDEW2+) with fixed baud rate (OBIS Codes)
Buffer size:	745 bytes
Rate input:	Max. voltage: 230VAC (-20% / +15%) max. current: 2mA
Pulse output:	Wipe, according to DIN 42864 (S0 output) max. voltage: 265VAC/DC max. current: 50mA min. voltage: 5VDC

Dimensions

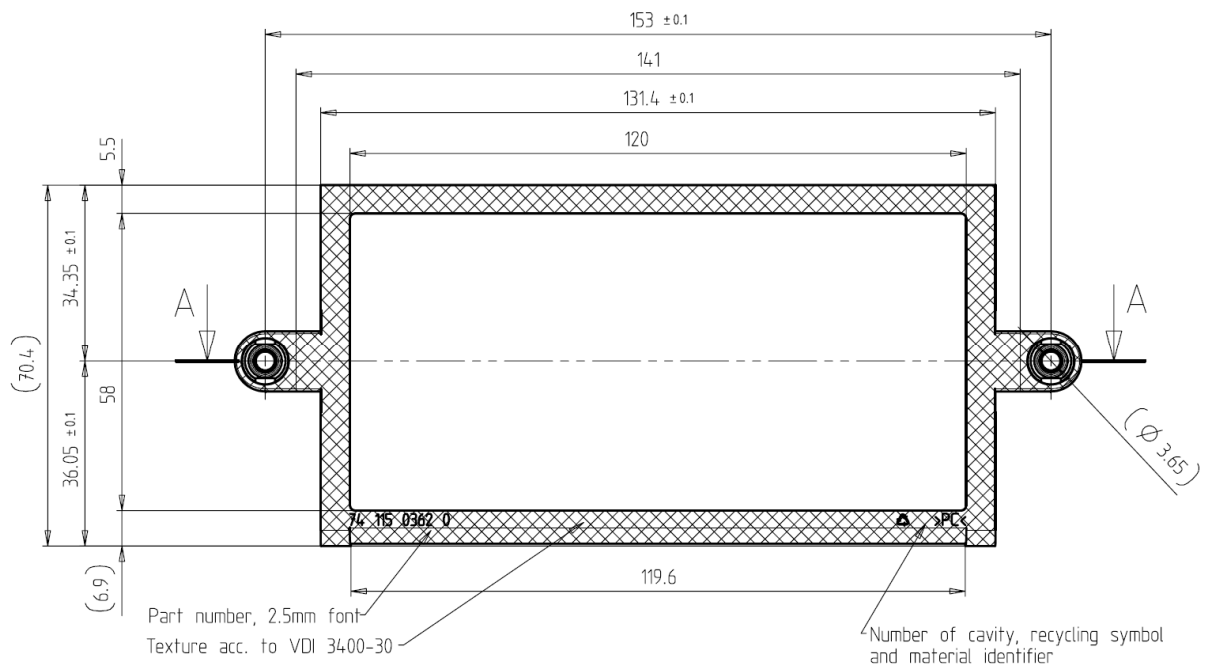

Terminal assignment

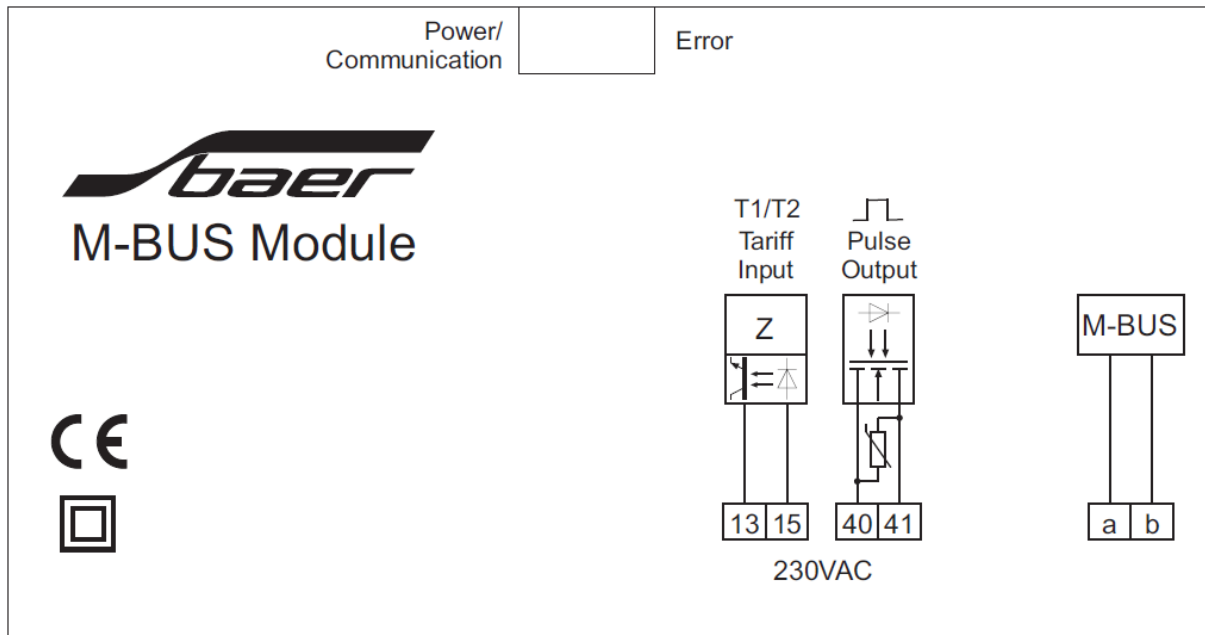

Power connection via connection spring:

Connector	Description
L1	Phase (Live) 230VAC (-20% / +15%) / 50Hz
N	Neutral

Terminal block:

Terminal	Description (according to VDEW)
13	Rate input (TE1/2)
15	Rate input (G1)
40	Pulse output (G3)
41	Pulse output (AA/+AA)
a	M-Bus
b	M-Bus